

Install



GenuineSaab.com

ITEM: Shifter Upgrade (KIT)
FITS: Saab 9-3 99, NG900 94-98
DATE: 12.21.10

GenuineSaab.com
Taliaferro Imports, Inc.
525 N Prince Ln
Springfield, MO 65802
T 417.831.SAAB M-F 8-5
parts@genuinesaab.com

All information copyright 2010
No reproduction permitted.

Supplementary install info for 94-99 NG900 / 9-3 Shifter install. This is for the kit option with new shaft. You will need some basic tools and dremel or other grinder to enlarge the base.

Here is the kit you will get. 3 mounting bolts, 3 Nuts and 3 Star washers and the shifter kit. It is the same assembly if you get the bolt on kit. This eliminates sending in the core. Also included is the template.

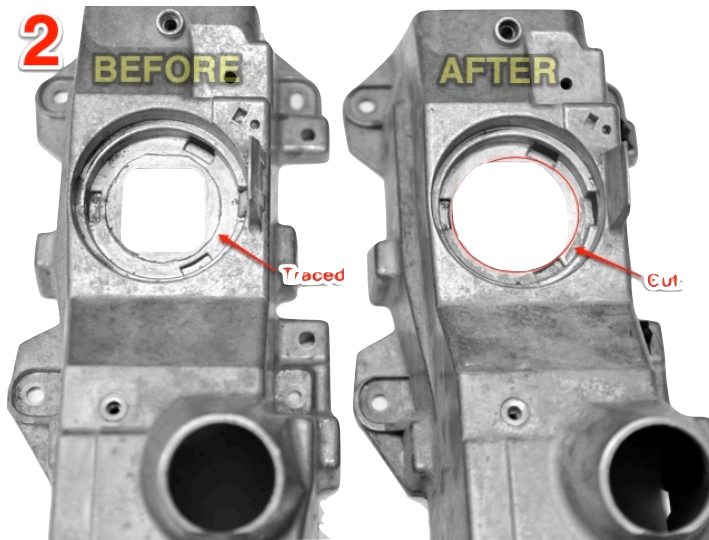
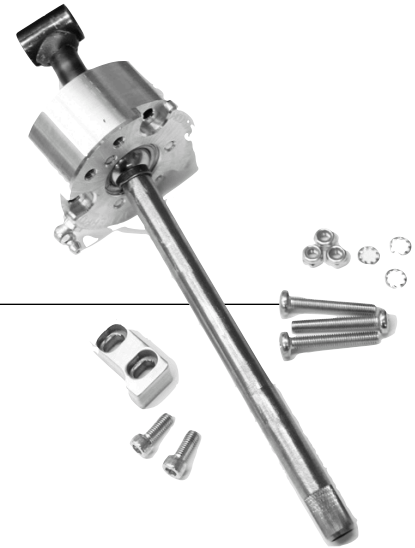

• Modifying the base. (Fig. 2) After cutting the template and marking the base you will need to cut the base out. Die grinder works ok. Make sure to remove all the burrs and shavings when you are done.

• Assembly. (Fig. 3) Start with

the star washers directly under the head of the 3 bolts. Stand them in the base. The head and washer should grab under the lips just like the stock plastic.

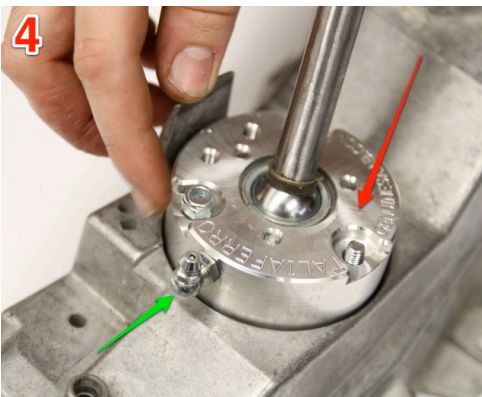

• While holding the bolts in you need to slide the bearing mount over the bolts. (Fig. 4) Make sure the grease fitting is pointed forward. When it is pressed down by hand tap it in place to make sure it is seated.

Install



GenuineSaab.com

- To tighten the bolts squeeze the heads to the housing with a pair of pliers. (Fig. 5, 6) Not too tight or you can crack the base.

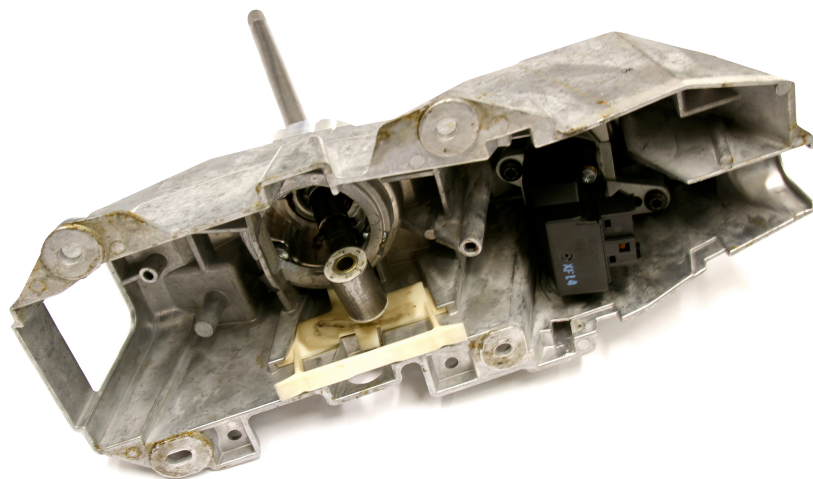
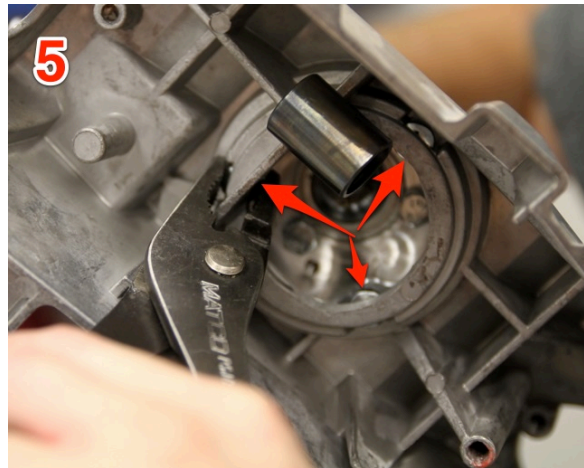

When you are done this is what the base should look like before reinstall. Don't miss the white plastic clip on the side.

GenuineSaab.com
Taliaferro Imports, Inc.
525 N Prince Ln
Springfield, MO 65802
T 417.831.SAAB M-F 8-5
parts@genuinesaab.com

All information copyright 2010
No reproduction permitted.