

Operation

For US and CA markets

A radio contact box (349) with radio and amplifier is mounted in the fascia.

Some variants also have a contact box (350) with CD player/equalizer or equalizer/control panel for CD changer mounted in the centre console.

An amplifier (351) for the rear loudspeakers is installed under the front passenger's seat. The front loudspeakers are driven by the amplifier in the radio contact box.

The contact boxes for the radio and CD player/equalizer as well as the amplifier under the front passenger's seat are wired to each other by means of screened signal cables fitted with DIN connectors.

A motorized aerial (256) is fitted on the left-hand side of the luggage compartment.

Some cars are equipped with CD changer 355 located in the luggage compartment.

Radio contact box 349

Two blade fuses, 5 A and 10 A, are fitted at the bottom of the contact box behind the radio.

Amplifier 351

A 15 A blade fuse is fitted to the amplifier between the contact housings.

The amplifier has a 3-position selector switch for the fader settings.

- 1 = 900CV, 9000, 4-door
- 2 = 900, 3-door and 4-door
- 3 = 9000, 5-door

Power supply

The following cables are connected to the upper 10-pole connector H10-3 shown in the wiring diagram:

Red (pin 1)—positive supply via fuse 19 which is supplied directly from the battery (regardless of the position of the ignition switch).

Red (pin 4)—positive supply via the ignition switch and fuse 27. The radio is operative when the ignition switch is in the parked or drive position.

Black (pin 5)—earth

Green (pin 6)—for control of motorized aerial 265. The motor of the aerial is supplied with current via fuse 6.

Grey (pin 7)—If the radio is on when the engine is started, the loudspeakers may be blown. To prevent this, the amplifier receives a signal to reduce the signal to the loudspeakers when the engine is started.

Brown/white (pin 8)—Dial lighting. The supply is taken from instrument lighting rheostat 16.

Other markets

Cars for other markets are prepared for radio installation by the fitting of two 10-pole connectors, one for the power supply, etc. (see above) and one for connection of the loudspeakers. The only difference between radio installation for the US and CA markets and radio installation for other markets is that the upper connector has three earth connections on pins 5, 9 and 10.

The connectors for the motorized aerial are located behind the trim on the left-hand side of the luggage compartment.

Fault-tracing hints

- 1 Check the supply to the radio and check the earth connections.
- 2 Check the built-in fuses in the radio contact box and amplifier.
- 3 Check the connectors.
- 4 Check the wiring for open-circuits and short-circuits to earth.

Locations of components

20	Ignition switch on the right-hand side of the steering column
22A	Fuse holder behind the access panel in the glove box
213	Pictogram in the combined instrument
230	Distribution terminal +30 in the electrical distribution box behind the glove box
265	Motorized aerial, on the left-hand side at the rear
266	Loudspeakers, two in the fascia, two in the parcel shelf
267 (H10-2) (H10-3)	10-pole connector in the centre console
349	Radio contact box with amplifier in the centre console
350	Contact box for CD player/equalizer in the centre console
351	Audio system amplifier (US, CA) under the right-hand front seat
355	Automatic CD changer (US, CA) in the luggage compartment on the left-hand side at the motorized aerial
	<i>2-pole connector</i>
H2-42	At prepared location of motorized aerial on the left-hand side
H2-64	At the rear left-hand loudspeaker, not audio system
H2-65	At the rear right-hand loudspeaker, not audio system
	<i>6-pole connector</i>
H6-9	Connection of amplifier to radio compartment in the centre console.
	<i>8-pole connector</i>
H8-7	Radio console connection
	<i>10-pole connector</i>
H10-14	In the luggage compartment on the left-hand side at the filament monitor
	<i>12-pole connector</i>
H12-3	Radio compartment connection
	<i>13-pole connector</i>
H13-3	Connection between CD changer and CD player
G8	Earthing point, fascia, at the front left-hand loudspeaker socket
G27	Earthing point, motorized aerial

Components

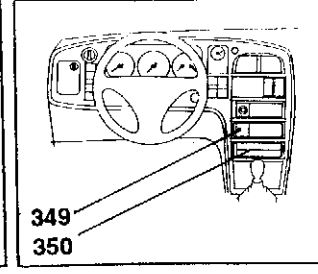
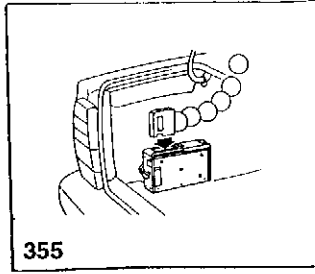
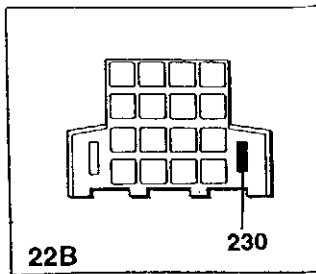
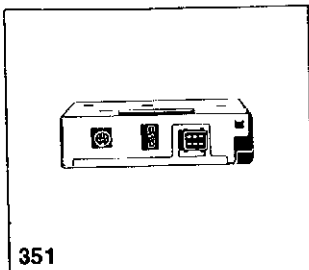
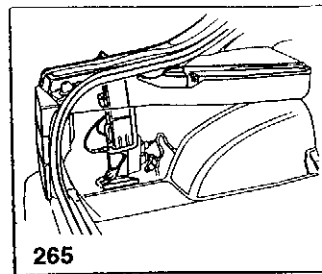
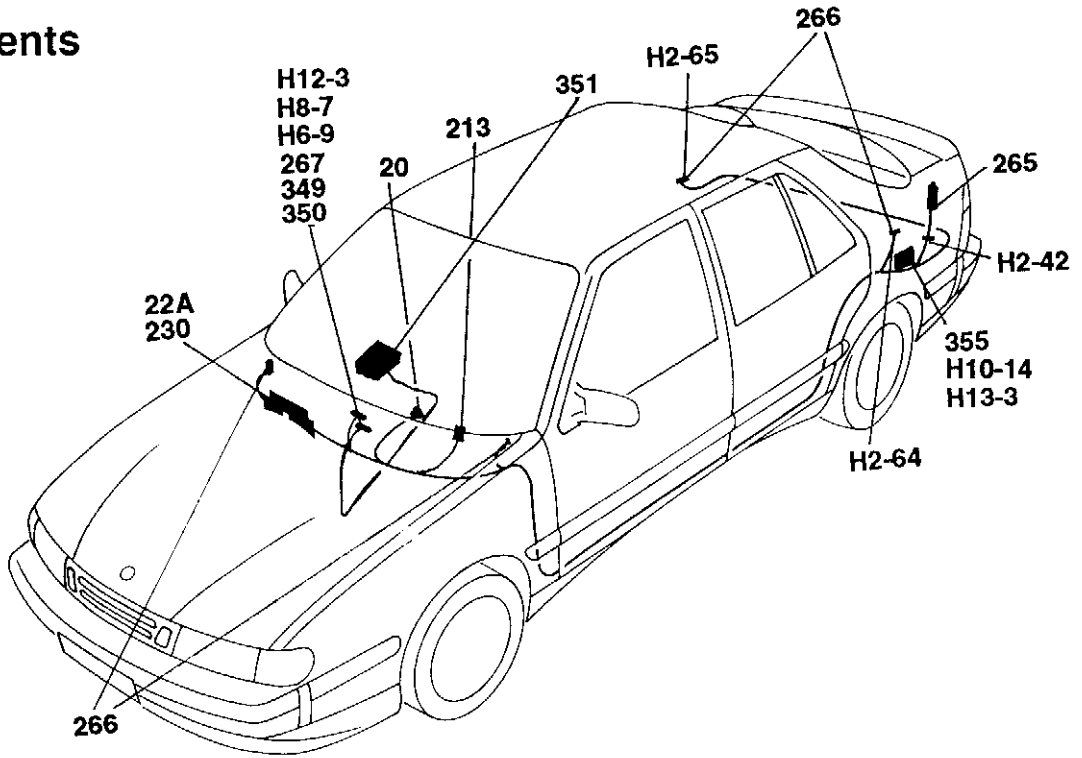

Radio installation

